

# AERODYNAMIC DESIGN FOR SUPERSONIC SPEEDS

By ROBERT T. JONES\*

National Advisory Committee for Aeronautics  
Ames Aeronautical Laboratory  
Moffett Field, California

*Summary*—The aerodynamic phenomena that may profitably be employed by the designer at subsonic speeds seem now to be well understood. At supersonic speeds such phenomena show a greater and more interesting variety. Search for the minimum number of guiding principles of design thus becomes more difficult and more dangerous.

Studies which can cover an adequate range of geometrical form are at present limited to the linearized version of aerodynamic theory. Such studies, especially those by variational methods, have disclosed certain basic principles of design for aerodynamic efficiency. In present-day experiments, however, the indicated trends are rather quickly confronted with effects of viscosity and nonlinearities. While the theory indicates that good values of aerodynamic efficiency are possible at supersonic speeds it is not yet clear how closely these expectations may be approached in practice.

In the present paper several arrangements of supporting surfaces and bodies are discussed and in some cases comparisons of theory and experiment are made. Finally, certain phenomena connected with lift and drag in a rarefied medium are considered briefly.

## INTRODUCTION

In its earlier development the subsonic airplane showed a great variety in the arrangement of airfoils, bodies, and other parts. For the past 15 or 20 years, however, those airplanes which have passed the tests of experience have shown little alteration in basic form. The aerodynamic principles which have determined this form seem now to be well understood and agreed upon.

The situation is different in the case of the supersonic airplane. Here the aerodynamic rules seem more complex. No clear direction toward a specific form is evident. Our theoretical investigations have taken a rather wide range—seeming in some cases rather far removed from practical questions.

In the present paper we shall review some of the recent theoretical and experimental work in supersonic aerodynamics with its practical application in mind.

\*Aeronautical Research Scientist

## COMPONENTS OF DRAG

When considering the drag of a complete airplane it is natural to simplify our thinking by dividing the drag into components according to differences in origin. One possibility here is to assign a drag to the individual parts of the airplane and then allow for a certain "interference" between the various components. This scheme is not completely satisfactory at supersonic speeds since the individual drags often tend to be outweighed by the interference. A somewhat more satisfactory division associates a component of the drag with lift-producing elements, elements of volume or thickness, and a component of surface friction. Here again the interference must not be discounted and it is necessary to guard against the acceptance of any such division as having a fundamental significance.

Thus the division of drag according to normal pressure and skin friction or "tangential pressure" seems a natural one, and yet situations arise in which this convention is not appropriate. In the case of a cooled body in a rarefied gas stream the resultant stress acts nearly in the stream direction, independently of the inclination of the surface. Here the resultant affords a simpler description than any of its components.

If we accept tentatively the division according to lift, volume, and surface area, then it is possible to trace the variation in the relative magnitude of these items as the Mach number increases. The range of low supersonic speeds is characterized by the development of large pressures on surfaces having a small inclination. Thus the drag due to thickness or volume is relatively large in comparison with the drag due to lift. At the same time any disturbance causes an extensive lateral influence, giving rise to pronounced interference effects. The surface friction is, however, hardly changed from its subsonic value, provided the increased tendency toward separation can be avoided.

At higher speeds the Mach waves bend back so that the zone of influence is contracted laterally into a smaller space around the body. The pressure developed by a given surface inclination becomes smaller in proportion to the dynamic pressure. For this reason the drag associated with the thickness is reduced. To support a given lift the wing must have a larger angle of attack, so that the drag due to lift is increased. The friction coefficient with either laminar or turbulent flow diminishes, but not as rapidly as the normal pressure.

The drag arising from the volume of the wings or bodies is most pronounced at low supersonic speeds near  $M = 1.0$ . For airplanes intended to fly in this range a proper distribution of volume according to the area rule is important. As in the case of the lift distribution, however, our studies have shown that the minimum of the drag is not a sharp minimum, but there exist many smooth shapes near the optimum which have essentially the minimum drag. From the designer's standpoint the influence of the over-all proportions is perhaps the dominant influence, the wave

drag being reduced most effectively, of course, by extending the volume in the flight direction.

#### MINIMUM DRAG OF LIFTING SURFACES

In the problem of minimum drag, as previously considered by the present writer<sup>(1)</sup>, the plan form of the wing is assumed to be given as well as the total lift. The result provides a certain unification of subsonic and supersonic airfoil theories through the artifice of a "combined flow field". By considering this problem from a different point of view, M. N. Kogan<sup>(2)</sup> has recently given a derivation in which the significant quantities seem to have a closer relation to the physical phenomena. Rather than consider a reversed motion of the wing, Kogan utilizes the reversed Mach wave as a control surface in applying the momentum theorem to the calculation of drag. As a result of this choice, the expression for the drag reduces to the Dirichlet integral of the local disturbance velocities projected on this surface. Thus

$$D = \frac{1}{2}\rho \int_r \int (\varphi_y^2 + \varphi_z^2) dy dz \quad (1)$$

while the lift is given by

$$L = \rho U \int_r \int \varphi_z dy dz \quad (2)$$

Here  $\varphi_y$  and  $\varphi_z$  are the  $y$  and  $z$  components of the disturbance velocity after projection on the characteristic surface  $r$ . The lift is thus proportional to the downward momentum of this lateral flow and the drag to its kinetic energy. Now, of flows having a given momentum, the one having the smallest kinetic energy is that one which follows the streamlines of an incompressible fluid. Hence a wing of minimum drag should, if possible, produce on this rear characteristic surface a flow satisfying Laplace's equation in two dimensions, that is:

$$\varphi_{yy} + \varphi_{zz} = 0 \quad (3)$$

The projected velocity distribution on the reversed characteristic surface thus plays a role similar to the lateral velocity distribution in the Trefftz plane in ordinary wing theory. Unlike the Trefftz plane, however, the zone of disturbance on the reversed characteristic surface is limited in extent. Beyond the Mach waves from the leading edge the lateral entrainment of the wing ceases, leading to the boundary condition  $\varphi = 0$ , so that the wing operates effectively on a limited jet of air. The problem is thus analytically the same as that of a wing at low speed in an open jet wind tunnel (see Fig. 1). The increase of the induced drag which results from the limitation of the wing in the finite jet is exactly equal to the "wave drag" of the wing in unlimited supersonic flow. Wings having

short fore-and-aft dimensions have a small area of entrainment, as shown by Fig. 2. The effect of increasing the Mach number is shown in Fig. 3.

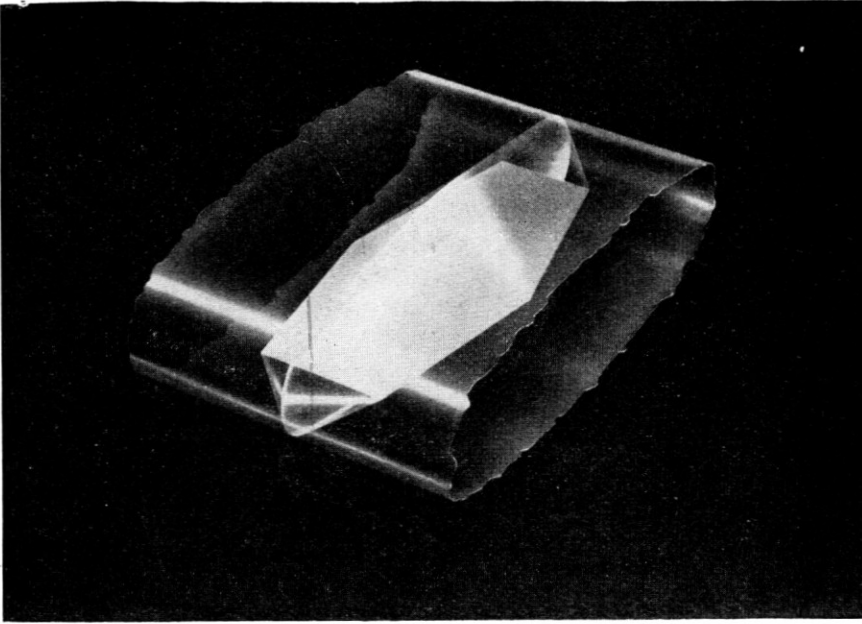

FIG. 1. Equivalent incompressible jet.

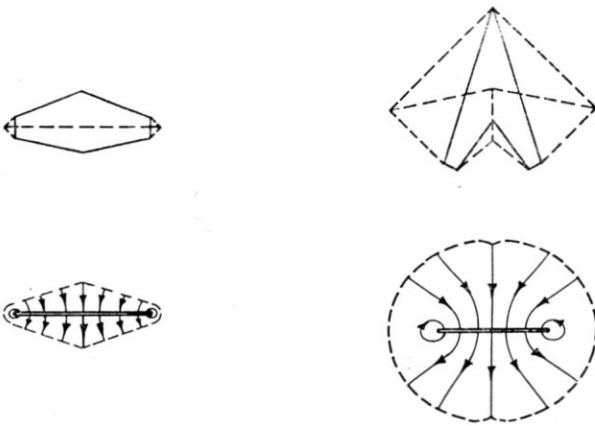

FIG. 2. Effect of fore-and-aft dimension of wing on area of lateral entrainment.

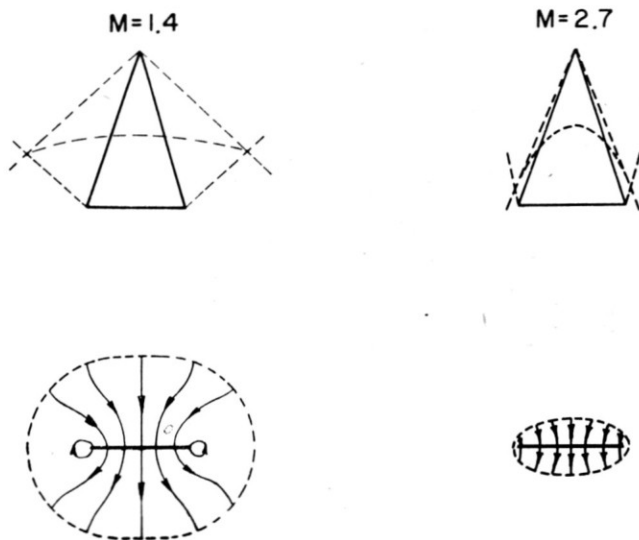

FIG. 3. Effect of Mach number on area of lateral entrainment.

We recall the formulas of Prandtl and Munk for lift and drag of the wing at low speed, that is

$$L = \rho w U S' \quad (4)$$

$$D = \frac{1}{2} \rho w^2 S' \quad (5)$$

where  $w$  is the downwash and  $S'$  is the area of virtual additional mass of the wing's trace. In the new theory these same formulas will apply at supersonic speed if the area  $S'$  is replaced by the area of virtual mass of the wing trace in the finite jet as limited by the Mach waves.

It seems unlikely that a result of this kind, referring to principles of momentum and energy, would be strictly limited to the linearized version of the wing theory. Following this thought, M. D. Van Dyke and I have recently found that equations (1), (2), and (3) remain valid even when quantities of second order in the velocities and pressures are retained.

As Ward has indicated<sup>(3)</sup>, the relation between the characteristic trace of the wing and its plan form is not unique. Now Kogan's analysis yields the minimum drag consistent with a given characteristic trace (including the vortex trace) and a given total lift, or, by an obvious extension, a given spanwise load distribution, but it does not give necessarily the minimum drag associated with a given plan form, only a lower bound. For, consider two outline shapes, one lying within the other, yet both having the same characteristic trace, so that the two-dimensional solution is the same for both. Subtract one flow from the other: the disturbance is canceled completely at the characteristic surface, indicating zero drag, yet a dis-

tribution of lift remains in the region of the wings. Thus in determining the minimum drag for a specified characteristic trace we are also determining the associated plan form. For the solution of the minimum problem when the plan form is given we have to return to the criterion of constant downwash given earlier.

E. W. Graham<sup>(4)</sup> has shown that a result similar to Kogan's can be derived by utilizing the idea of the combined flow field. Graham's analysis provides further a simple determination of the loadings of the wing when integrated in various oblique directions. Graham's analysis brings out the following interesting question: Suppose we have a surface distribution of lift  $l(x,y)$  and suppose the projected linear loadings  $\Pi(x_0,\alpha)$  obtained by integrating  $l(x,y)$  along lines in various directions  $x = x_0 + \alpha y$  are known. Can the surface distribution  $l(x,y)$  be determined from  $\Pi(x_0,\alpha)$ ?

Graham<sup>(5)</sup> gives the following result; if

$$\Pi(x_0,\alpha) = \iint l(x,y)\delta(x-x_0-\alpha y)dx dy = \int l(x_0+\alpha y,y)dy \quad (6)$$

then

$$l(x,y) = \frac{1}{2\pi^2} \int \int \frac{\partial \Pi}{\partial x_0} \frac{dx_0 d\alpha}{x-x_0-\alpha y} \quad (7)$$

A somewhat more symmetrical relation can be achieved if we substitute for the Dirac delta function,  $\delta$ , its equivalent Cauchy integral formula:

$$\int f(x)\delta(x-x_0)dx = \frac{1}{2\pi i} \int_{-\infty}^{\infty} \frac{f(x+0i)-f(x-0i)}{x-x_0} dx = f(x_0)$$

Then we may write

$$\Pi(x_0,\alpha) = \frac{1}{2\pi i} \int \int \frac{l(x+0i,y)}{x-x_0-\alpha y} dy dx \quad (8)$$

The integrations should extend over the largest plan form consistent with the projected lengths of the loadings  $\Pi$ , though the lift distribution  $l(x,y)$  may not do so.

Studies by variational methods often establish essential relations with greater clarity than other methods. Here the relation of the drag to the area of entrainment and to the momentum and energy of the downwash flow is perhaps more significant than the relation for the drag to be an absolute minimum. Following this thought we may seek functions for  $\varphi$  which satisfy the condition  $\varphi = 0$  on the outer boundary of the characteristic trace and  $\varphi_z = \text{constant}$  on the wing trace, but which satisfy  $\varphi_{yy} + \varphi_{zz} = 0$  only approximately. Thus Heaslet and Fuller<sup>(6)</sup> find quite simple expressions for the drag of wings having the plan form of a *hyperbola* by relaxing this latter condition. Their solutions correspond to exact minima of the drag for special positions of the center of pressure.

The problem of minimum drag when both the lift and the center of pressure are fixed has been considered by P. Germain<sup>(7)</sup>. In this case the divergence of the velocity field is not zero as in equation (3) but has a constant value. From the practical standpoint it may be noted that a wing whose width increases toward the rear generally has a smaller drag when the centroid of the lift distribution is placed ahead of the aerodynamic center. Thus we may say that the triangular wing has a "negative trim drag". The optimum loading of wings having fore-and-aft symmetry, however, acts at the middle of the wing, behind the aerodynamic center. Hence wings having fore-and-aft symmetry or wings whose width decreases toward the rear (e.g., a reversed triangular wing) may be expected to have a positive trim drag.

#### YAWED AND SWEEPED WINGS

With planar wings the wave drag is reduced as the lift distribution is extended in the flight direction, while the vortex drag is reduced by extending the span. At the same time the friction drag is reduced by diminishing the exposed area of the wing. At subsonic speeds the last two considerations are effective and they lead to wing forms approaching a lifting line perpendicular to the flight direction. At supersonic speeds the added condition on the length leads to a long, narrow wing placed at an angle of yaw.

It is interesting to analyze the yawed lifting line in terms of its area of entrainment. The forward and reversed Mach waves are simply circular cones drawn from the ends of the line. At subsonic angles of yaw the cones are displaced laterally so that the contour of their intersection, which outlines the equivalent jet, is an ellipse. The area of this ellipse vanishes rapidly, however, and disappears completely as the lifting line approaches the Mach angle. The area of entrainment is zero and the wave drag given by the theory is infinite at supersonic angles of yaw.

If we convert a yawed wing into a swept wing by bending it at the middle, keeping the same structural slenderness, we see that the length in the flight direction is reduced to about one-half. The wave drag is then increased, so that the potential lift-drag is invariably smaller for the bilaterally symmetric arrangement.

Figure 4 shows the estimated lift-drag ratios for a slender elliptic wing at various angles of yaw. The Mach number considered here is 1.4, so that the transition from flow of the Kutta-Joukowski type to the Ackeret type occurs in the vicinity of 45°. The best angle of yaw is 30°, placing the wing at a transverse Mach number of approximately 0.70. The lift coefficient required for maximum  $L/D$  at this point is, however, too high for the Kutta-Joukowski type of flow; hence, additional curves have been computed to show the effect of limiting the lift coefficient based on the transverse component of velocity to values of 1.0 in one case and 0.5 in another.

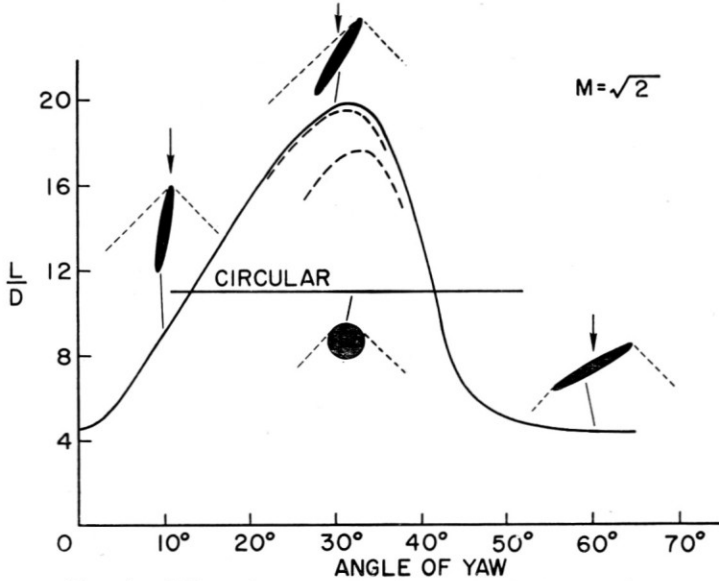

FIG. 4. Effect of yaw on lift-drag ratio of elliptic wing.

Whether the wing is yawed or swept, the potential lift-drag ratio increases almost without limit as the aspect ratio is increased. The practical limit is reached when the lifting pressures become so great that Kutta-Joukowski flow is no longer possible. A similar situation arises in the design of a sailplane. Here the lift-drag ratio increases rapidly with aspect ratio up to the point at which the optimum lift coefficient begins to exceed the maximum lift coefficient of the wing sections, that is, when Kutta-Joukowski flow is no longer possible.

Figure 5 shows the results of some experiments made by Robert T.

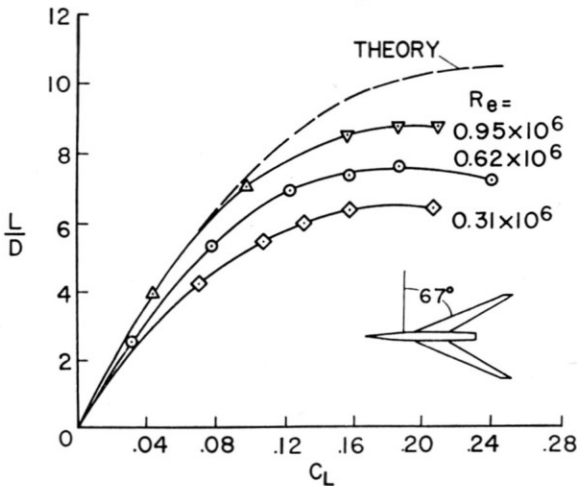

FIG. 5. Effect of Reynolds number on lift-drag ratio;  $M = 1.53$ .



Madden at Ames Laboratory on a swept-wing model at a Mach number of 1.53. Here the limitation imposed by the action of viscosity on the performance of the long narrow swept wing is evident—especially at low Reynolds numbers. The sweep angle in this case is  $67^\circ$ .

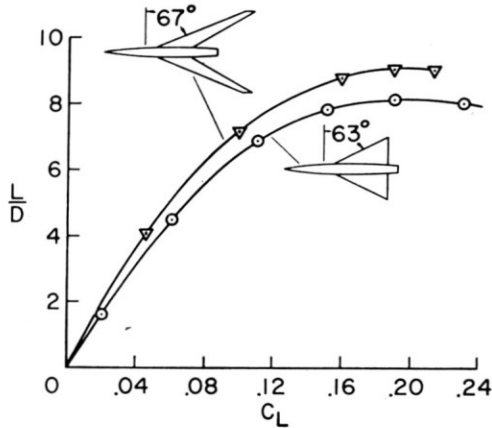

FIG. 6. Effect of wing plan form on  $L/D$ .

Figure 6 shows experimental values of  $L/D$  obtained by Hall and Heitmeyer<sup>(8)</sup> for a model having a triangular wing. Their values are compared with the highest curve for the swept wing. The models have the same fuselage and are tested at comparable Reynolds numbers.

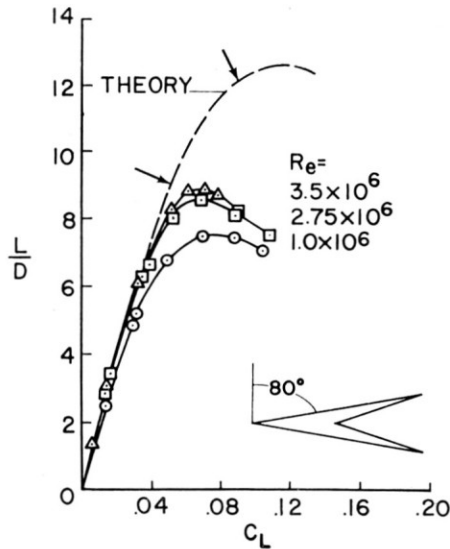

FIG. 7. Effect of Reynolds number on lift-drag ratio;  $M = 3.0$ .

Figure 7 shows results of experiments made by Elliott Katzen<sup>(9)</sup> of Ames Laboratory on a wing having  $80^\circ$  of sweep. The Mach number in

this case is 3.0. The airfoil section of the model shown is the well-known Clark Y, which proved superior to especially cambered sections at these Reynolds numbers.

The curve termed "theory" on the figure (Fig. 7) is simply an estimate in which the limitation on the transverse lift coefficient was not imposed. At the peak of this curve the lift greatly exceeds the maximum lift coefficient of the Clark Y airfoil section in two-dimensional flow. The two arrows shown indicate values of 1.0 and 2.0 for this transverse lift coefficient. There is clearly an uncertainty in our considerations here since the wing has widely different angles of sweep at the leading and trailing edges.

In spite of their limitations, the swept wings nevertheless maintain a margin of superiority over rectangular or triangular plan forms except at the lowest Reynolds numbers. The narrow swept wings, however, have a greater structural weight and a smaller usable lift coefficient for landing. Unless their potential  $L/D$  ratios can be approached more closely in practice, their use is difficult to justify in many applications.

#### REDISTRIBUTION OF LIFT BY FUSELAGE

In steady flow at subsonic speeds the fore-and-aft influence of the wing is complete so that concentration of the lift within a narrow chordwise dimension causes, theoretically, no increase in the pressure drag associated with the lift. At supersonic speeds the unlimited forward influence of the wing is lacking, and the lifting system itself must have an extension in the flight direction if lift is to be produced with a minimum of wave dissipation.

Since the fuselage of a supersonic airplane tends to be long and slender, the question of distributing a part of the lift along the fuselage arises. The possibilities inherent in this suggestion have been studied at Ames

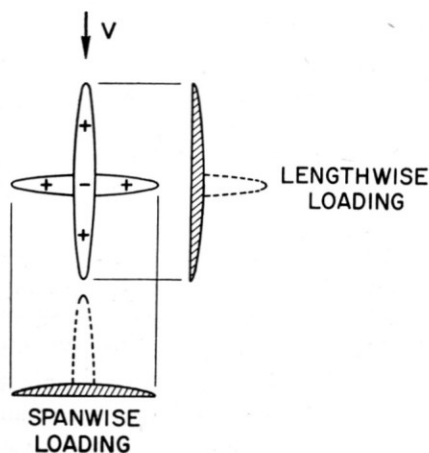

FIG. 8. Distribution of lift along fuselage.

Laboratory and by the theoretical aerodynamics group at the Douglas Aircraft Company<sup>(10)</sup>.

The simplest aspect of the problem appears if we consider distributions of lift on two narrow surfaces in the form of a cross (see Fig. 8). Both the spanwise and the lengthwise loadings should have the form of smooth regular functions. However, if appreciable lift is carried on the "fuselage" then the spanwise loading will show an undesirable concentration at the center. Similarly, a peak in the lengthwise loading appears from the lift carried on the "wing". Desirable loadings appear when the wing and the fuselage each carries a lift approximately equal to the specified value  $L$  except at the center, where a downward load of magnitude  $-L$  must appear. Hence the fuselage should carry positive lift front and rear but negative lift in the middle.

Detailed calculations show that large gains are to be expected if the theoretical redistribution of lift by the fuselage can be accomplished in practice. The lifting pressures required on the fuselage are, however, of the same order of magnitude as those developed by the wing. According to present experience lifting forces of this magnitude cannot be developed by bending or inclining a slender body of revolution without causing flow detachment and the formation of discrete vortices. Further study of this type of favorable fuselage interference should perhaps include some account of flow detachment or, better still, some means for avoiding it.

#### HIGH WING ARRANGEMENTS

Interaction between lift and volume begins to appear in the drag when the wing and fuselage are separated vertically. This interference is favorable in the case of a high-wing monoplane, but adverse for the low wing. More generally, we may consider an interaction between surfaces developing forces in a cross-stream direction and elements of volume. Such interactions do not appear at all in the so-called "supersonic area rule". They appear in Hayes' formula<sup>(11)</sup>, however, since the latter is valid quite generally for distributions of singularities in three dimensions. An equally general formulation is given by Lomax and Heaslet<sup>(12)</sup>, which expresses the drag directly in terms of the volume distribution and the lateral forces. In the well-known Ferrari ringed body the interaction between these terms may be considered complete, since the wave drag is canceled exactly.

Such an arrangement may be made to develop lift, but the wave cancellation is then of course incomplete. The most efficient way to gain lift seems to be to omit the lower half of the ring, thus creating a kind of "parasol" monoplane with a highly arched wing (see Fig. 9). The possibility of obtaining high lift-drag ratios with wing-body combinations of this form has been carefully investigated in papers by Lomax and Heaslet of the NACA (ref. 12, and unpublished) and Beane and Ryan of the Douglas Company<sup>(13)</sup>. Figure 9 illustrates the wing-body arrangement and shows

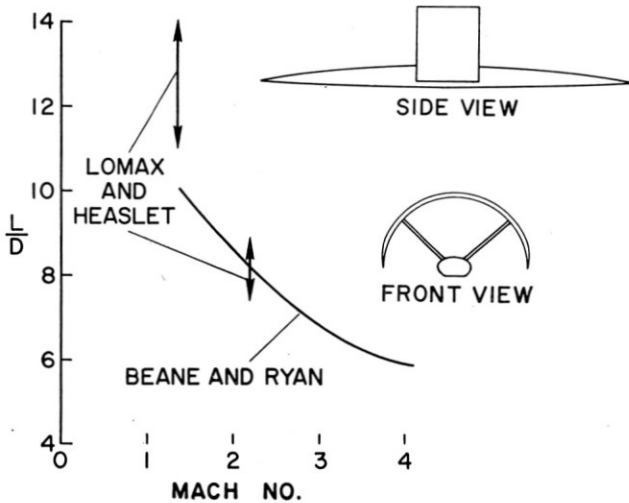

FIG. 9. Estimated lift-drag ratio of body with arched wing.

some typical results at design conditions. As in the case of planar wings, important gains could be shown if the fuselage could be assumed to develop sizeable cross forces. When this possibility is discounted the lift-drag ratios fall considerably but not below those estimated for highly swept wings.

The arrows represent estimates made by Lomax and Heaslet for a wing, a body, and two supporting struts. The flattened body carries no net lift but does support a lift distribution. The wide band covered by the arrows is necessitated by the lack of experimental information on the magnitude of the cross forces that can be generated by body distortions. The curve represents estimates made by Beane and Ryan for a wing and body without the wing support system. Their body, however, was required to carry no lift, even locally. Further, their choice of the turbulent skin-friction drag coefficient was higher, 0.0030 as compared to 0.0025. The conclusion appears to be that the highly arched wing and body can have as high a value of  $L/D$  as the swept wing and body.

As in the case of the swept wing, the estimated  $L/D$  ratio increases if the wetted area can be reduced by reducing the wing chord. Here again we encounter the limitation imposed by the magnitude of the pressure coefficient. As the wing is made narrower the pressures on the wing increase. The wing pressures are moreover reflected to the rear of the body and increased by a focusing effect. Thus we may expect flow separation at the rear of the body. The influence of these phenomena on the actual characteristics of such an arched wing arrangement will have to be determined experimentally.

In the methods employed by Ferri<sup>(14)</sup>, and Rossow<sup>(15)</sup>, the physical aspect of interference phenomena is made evident. Considering the

interference between planar wings and bodies, these studies have shown definitely favorable effects for high-wing arrangements.

It will be interesting to try and determine a lower bound that might be approached by this method of drag reduction. Referring to Kogan's analysis we find that the conditions imposed on the downwash flow in the "equivalent incompressible jet" are unaltered by the presence of bodies, provided these do not extend beyond the characteristic envelope of the wing. The added bodies may bring the drag of a given wing closer to this lower bound. However, if a wing shape can be found which causes the streamlines of the downwash to follow the pattern of an incompressible flow, then the addition of bodies cannot reduce the drag, except as they may extend the lateral zone of influence of the wing-body system.

#### CANCELATION OF THICKNESS DRAG

At intermediate supersonic speeds the wave drag due to thickness can be reduced to small values by the phenomenon of wave reflection. There exists a great variety of three-dimensional toroidal shapes for which the wave system is entirely self-contained; that is, the wave resistance is zero at certain Mach numbers, as in the Busemann biplane. One such example with which we have experimented at Ames Laboratory is illustrated in Fig. 10. The model is essentially a tube so shaped as to produce

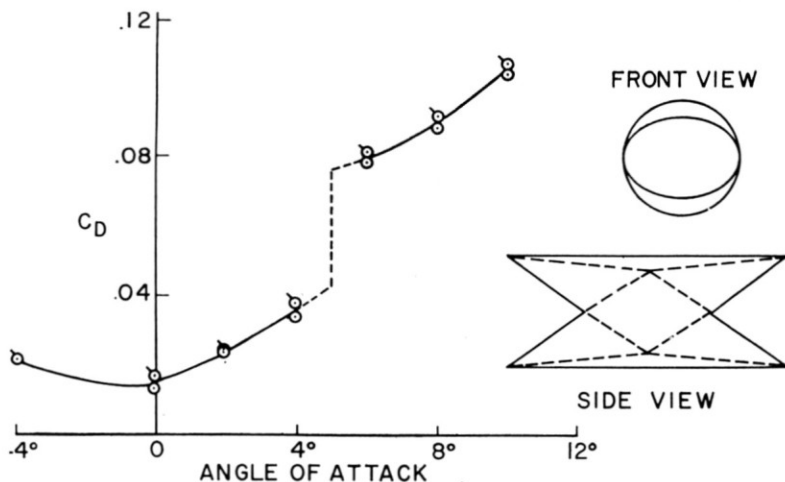

FIG. 10. Drag of tube having a planar wave system.

in its interior a finite portion of the plane wave system between the wings of a Busemann biplane. Such shapes are easily constructed by marking out a stream surface of arbitrary cross section in the undisturbed flow ahead and then calculating the inward deflections of this surface as it passes through the plane wave system of the biplane. Since the wave system has no lateral velocities (i.e., no components in the  $y$  direction),

the boundary conditions may be satisfied most conveniently by referring them to sections of the torus made by vertical planes (see Fig. 10).

Tubular bodies having no wave drag can also be made with multiple symmetry, or with complete rotational symmetry. However, such shapes ordinarily enclose regions in which the pressure rises to large values because of focusing. In the case of plane waves the reflection involves only a factor of 2—and this seems to be the smallest value obtainable.

The experiments were made by Loren Bright of Ames Laboratory and showed a negligible wave drag at the design Mach number of 2.0. The most complete wave cancelation, however, occurred at a slightly higher Mach number,  $M = 2.3$ . In Fig. 10 the drag is plotted against angle of attack at  $M = 2.0$ . At about  $5^\circ$  the wave system changes suddenly and the drag increases.

Similar experiments with a torus designed to produce an oblique (i.e., yawed) system of plane waves showed a somewhat more continuous behavior.

While the experiments showed that the wave drag associated with the volume could be eliminated, the tubular bodies developed rather low values of lift-to-drag ratio. It seems that the added surface area required to enclose the wave system increased the friction drag enough to overbalance the gain in wave drag. At still higher Mach numbers the friction drag becomes increasingly important relative to the thickness drag. The use of wave cancelation between interfering bodies or surfaces is more easily justified if the added surfaces are also desirable for some other reason, such as stabilization or control.

#### LIFT AND DRAG AT HIGH ALTITUDES

In his article "Superaerodynamics" in the *Journal of the Franklin Institute*, Feb. 1934<sup>(16)</sup>, Albert F. Zahm refers to flight in the upper atmospheric layers and states that "Space craft and projectiles must obey new or modified laws of air resistance. These may well be studied in high-vacuum wind tunnels or chambers, under guidance of mathematical theory". I remember Zahm's paper well, since I was a student of his at the time and made drawings for the figures that appear in the paper. I also recall that the paper was not accepted for publication by the journals to which it was first submitted. One is tempted to think that it might be a great service if journals published, in addition to their tables of contents, some notice of the rejected contributions.

Zahm considered the flow of individual particles of a tenuous gas and indicated the modifications needed for diffuse reflection or re-emission of molecules. In later papers<sup>(17,18)</sup>, E. Sanger and H. S. Tsien brought these considerations into closer contact with the physics of gases as based on kinetic theory.

At speeds approaching 20,000 feet per second, we may of course dispense with aerodynamic lift for cruising. However, there are indications

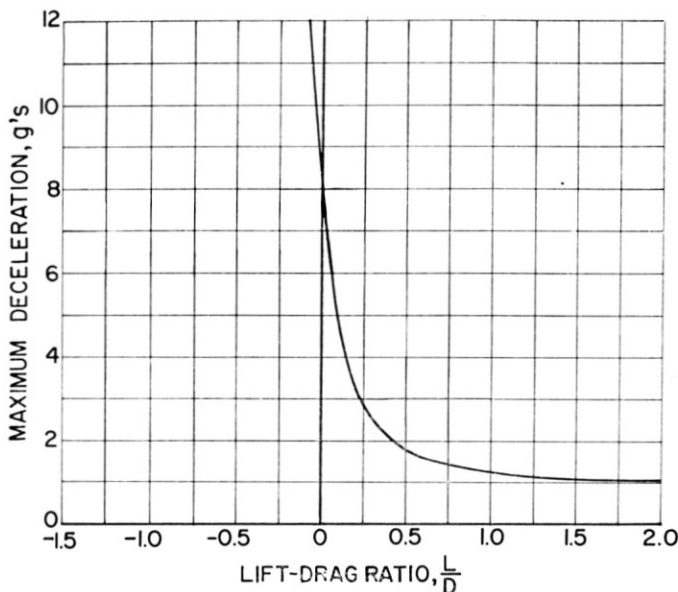

FIG. 11. Effect of lift-drag ratio on maximum deceleration for recovery of satellite.

that aerodynamic forces however small will play an important role in recovery from purely dynamic orbits or trajectories. Figure 11, prepared from calculations made by D. R. Chapman<sup>(19)</sup> of Ames Laboratory, shows the maximum decelerations encountered in a spiral descent from an initially circular orbit around the Earth. The descent is uncontrolled except that the direction of the resultant aerodynamic force is maintained at a fixed angle to the direction of motion, corresponding to a fixed  $L/D$  ratio. If the body develops no lift the maximum deceleration encountered is about 8 g. However, even small lift forces result in a much more uniform dissipation of the kinetic energy so that at a lift-drag ratio of one-half the maximum deceleration falls to about 2 g.

Even such small values of the  $L/D$  may prove difficult to achieve if the deceleration occurs at altitudes above 75 miles. Figure 12 illustrates

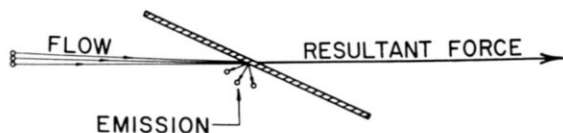

FIG. 12. Aerodynamic force on inclined plate in low-density flow.

the expected reaction on an inclined flat plate in air of extremely low density. The oncoming molecules are deposited on the plate and are emitted with thermal velocities corresponding to its temperature. For a relatively cool surface at high flight velocities the pressure due to emission

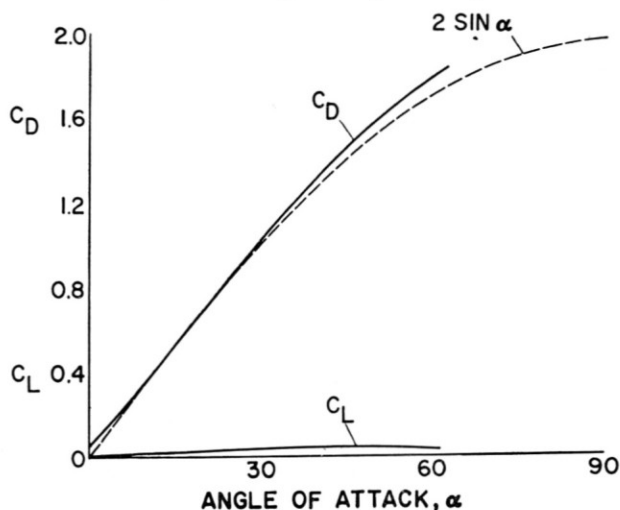

FIG. 13. Drag and lift coefficients on inclined flat plate in low-density flow.

can be neglected. Under these conditions the aerodynamic force is a drag, given by the relation

$$D = \rho U^2 S' \quad (9)$$

Here  $S' = S \sin \alpha$ , is the frontally projected area of the wing. Figure 13, prepared from data given in ref. 20, shows how closely this simple rule is obeyed by more precise calculations.

The loss of lift in free-molecule flow is a consequence of Knudsen's law, according to which the emission of molecules is independent of their angle of arrival at the surface. Such behavior is closely approximated in experiments conducted thus far<sup>(21,22)</sup>.

It seems unfortunate that the small departures from Knudsen's law have served to characterize a whole regime of rarefied gas dynamics as the region of "slip flow". The main effects seem to be related more directly to the "sticking" of the molecules rather than to their slipping.

Since the pressures developed at high speed are large compared to the ambient pressure, we may expect an extensive range of conditions in which the medium behaves as a gas in the vicinity of the body but as a molecular beam in the exterior flow. The investigation of this semi-continuous regime promises a great variety of yet undiscovered aerodynamic phenomena.

In conclusion, the writer wishes to express appreciation to his colleagues at Ames Laboratory for assistance in preparing this paper and to Prof. H. W. Liepmann of the California Institute of Technology for helpful discussions.



## REFERENCES

1. ROBERT T. JONES, The Minimum Drag of Thin Wings in Frictionless Flow. *J. Aeron. Sci.* Vol. 18, No. 2, pp. 75-81, Feb. 1951.
2. M. N. KOGAN, On Bodies of Minimum Drag in a Supersonic Gas Stream. *Prikl. mat. mech.*, Vol. XXI, pp. 207-212, 1957.
3. G. N. WARD, On the Minimum Drag of Thin Lifting Bodies in Steady Supersonic Flows, British A.R.C. 18,711, FM 2459, Oct. 1, 1956.
4. E. W. GRAHAM, The Calculation of Minimum Supersonic Drag by Solution of an Equivalent Two-Dimensional Potential Problem, Rep. SM-22666, Douglas Aircraft Co., Dec. 1956.
5. E. W. GRAHAM, A Geometrical Problem Related to the Optimum Distribution of Lift on a Planar Wing in Supersonic Flow, Rep. SM-23020, Douglas Aircraft Co., Nov. 1957.
6. MAX A. HEASLET and FRANKLYN B. FULLER, Drag Minimization for Wings and Bodies in Supersonic Flow, NACA Rep., 1958. (Supersedes NACA TN's 3289 and 4227.)
7. PAUL GERMAIN, Sur le Minimum de Traînée d'une Aile de Form en Plan Donnée, *C.R. Acad. Sci., Paris* Vol. 244, No. 9, Feb. 25, 1957.
8. CHARLES F. HALL and JOHN C. HEITMEYER, Lift, Drag, and Pitching Moment of Low-Aspect-Ratio Wings at Subsonic and Supersonic Speeds—Twisted and Cambered Triangular Wing of Aspect Ratio 2 With NACA 0003-63 Thickness Distribution, NACA RM A51E01, 1951.
9. ELLIOTT D. KATZEN, Idealized Wings and Wing-Bodies at a Mach Number of 3, NACA TN 4361, 1958.
10. R. M. LICHER, Reduction of Drag Due to Lift in Supersonic Flight by Distributing Lift Along a Fuselage. *J. Aero. Sci.* Vol. 23, No. 11, pp. 1037-1043, Nov. 1956.
11. WALLACE D. HAYES, Linearized Supersonic Flow. Rep. AL-222, North American Aviation, Inc., June 18, 1947.
12. HARVARD LOMAX and MAX A. HEASLET, Recent Developments in the Theory of Wing-Body Wave Drag. *J. Aero. Sci.* Vol. 23, No. 12, pp. 1061-1074, Dec. 1956.
13. B. J. BEANE and B. M. RYAN, Supersonic Drag Calculations for a Cylindrical Shell Wing of Semi-Circular Cross-Section Combined with a Central Body of Revolution, Rep. SM-22627, Douglas Aircraft Co., Oct. 1956.
14. ANTONIO FERRI, Recent Work in Supersonic and Hypersonic Aerodynamics at the Polytechnic Institute of Brooklyn; Paper given at the Conference on High Speed Aeronautics held by the Polytechnic Institute of Brooklyn, Jan. 22, 1955.
15. VERNON J. ROSSOW, A Theoretical Study of the Lifting Efficiency at Supersonic Speeds of Wings Utilizing Indirect Lift Induced by Vertical Surfaces, NACA RM A55L08, 1956.
16. A. F. ZAHM, Superaerodynamics. *J. Franklin Inst.* Vol. 217, pp. 153-166, 1934.
17. EUGEN SÄNGER, The Gas Kinetics of Very High Flight Speeds, NACA TM 1270, 1950.
18. HSUE-SHEN TSIEN, Superaerodynamics, Mechanics of Rarefied Gases. *J. Aero. Sci.* Vol. 13, No. 12, pp. 653-664, Dec. 1946.
19. DEAN R. CHAPMAN, An Approximate Analytical Method for Studying Entry Into Planetary Atmospheres, NACA TN 4276, 1958.
20. JACKSON R. STALDER and VERNON J. ZURICK, Theoretical Aerodynamic Characteristics of Bodies in a Free-Molecule-Flow Field, NACA TN 2423, 1951.

21. R. G. J. FRASER, *Molecular Rays*, Cambridge University Press, 1931.
22. IMMANUEL EASTERMANN, *Molecular Beam Applications to Transport Properties in Gases*, Presented at Second Biennial Gas Dynamics Symposium Technological Institute Northwestern University, Evanston, Illinois, Aug. 26-28, 1957.

## DISCUSSION

D. W. HOLDER\*: Has the author made experiments on wings with subsonic leading edges having sections other than the Clark Y section referred to in the lecture? What improvements of lift/drag ratio does he feel could be achieved by using suitably designed section shapes?

R. T. JONES: The wing having  $80^\circ$  sweep was tested initially with Clark Y sections and with its under surface flat. A cylindrical bending of the wing which increased the angle of attack at the apex and decreased it at the tips resulted in a slight improvement. A further gain might also result from a modification of the section shape, but the direction in which improvement lies is uncertain because of non-linear effects. Further details of these experiments are presented in NACA TN 4361 by Elliott D. Katzen.

G. H. LEE†: The remark by Mr. Jones that there are at present a great many possible layouts for a supersonic aeroplane is one that I should like to endorse. The fact that the designer has such a wide choice from which to select the layout makes his job at present difficult but very interesting; the additional fact that, to-day, there is some doubt regarding military and civil aeroplane requirements, adds to his problems.

In such circumstances, the general work being done by Mr. Jones and discussed in the lecture is very valuable in helping the designer to make his choice by giving him some idea of the relative aerodynamic "attractions", or the performance possibilities, of the different layouts, for example, the relatively small difference, shown in one of the slides, between the maximum  $L/D$  ratio for a "swallow-tail" and a delta wing suggests that in many cases  $L/D$  ratio would not be the decisive factor, though in certain applications the additional 10% or 15% could be most valuable.

I think we shall find the present paper most useful in making comparisons of this sort and in indicating ways of tackling the various aerodynamic problems which arise.

R. T. JONES: I am grateful to Mr. Lee for his comments and am glad to have my opinions reinforced by those of an experienced airplane designer. Perhaps the present uncertainty in military and civil airplane requirements is simply a reflection of our uncertainty concerning the physical limitation on airplane performance. Such requirements can usually be modified rather quickly following the introduction of a new phenomena or design principle.

\* National Physical Laboratory, England

† Deputy Chief Designer, Handley Page Ltd., England